

GENERAL ARRANGEMENT M.S. DARYA KARVI SCALE 1:200

FRONT VIEW

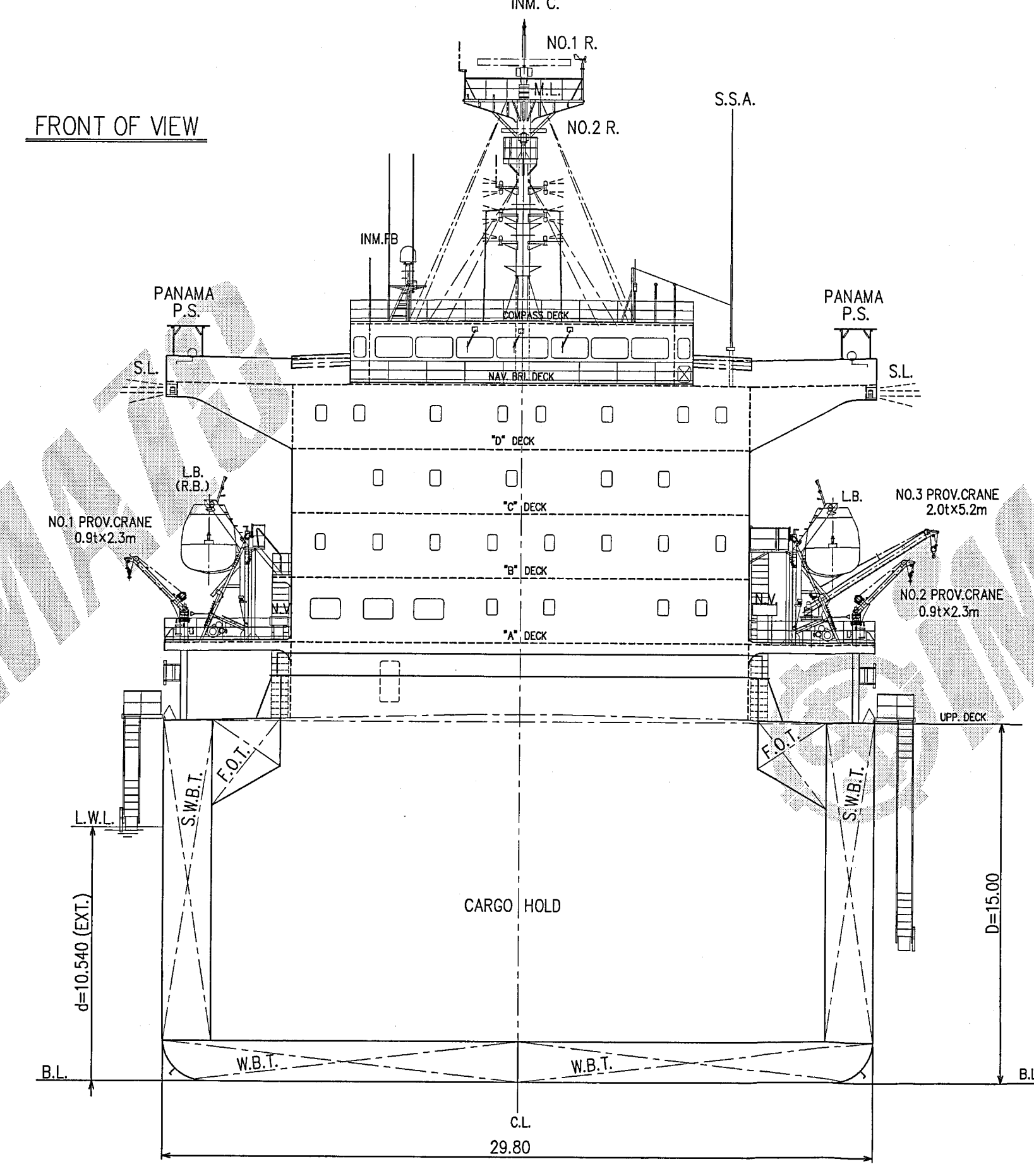

PROFILE

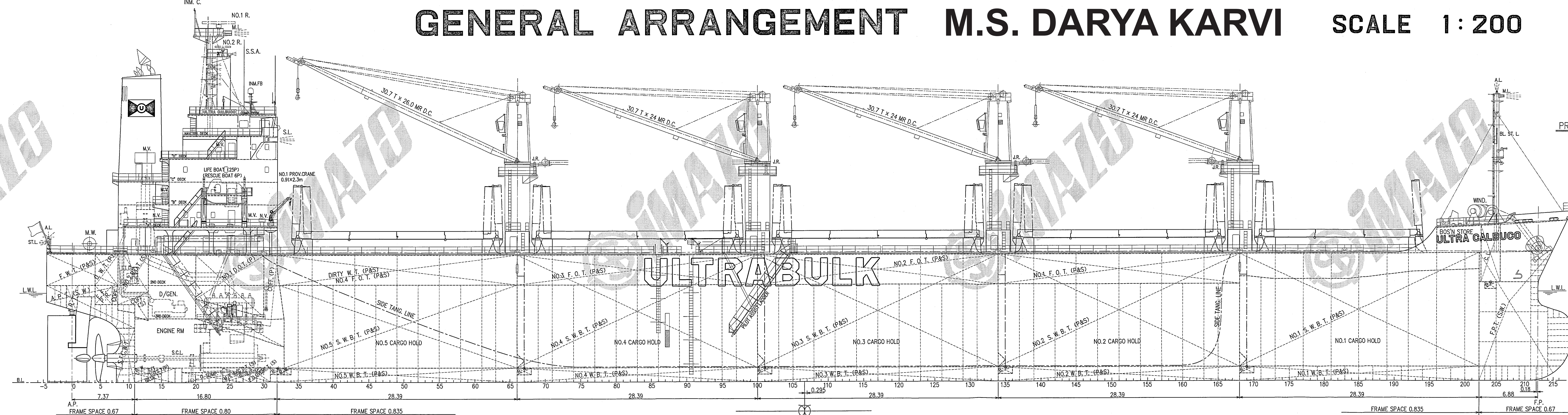

ULTRABULK

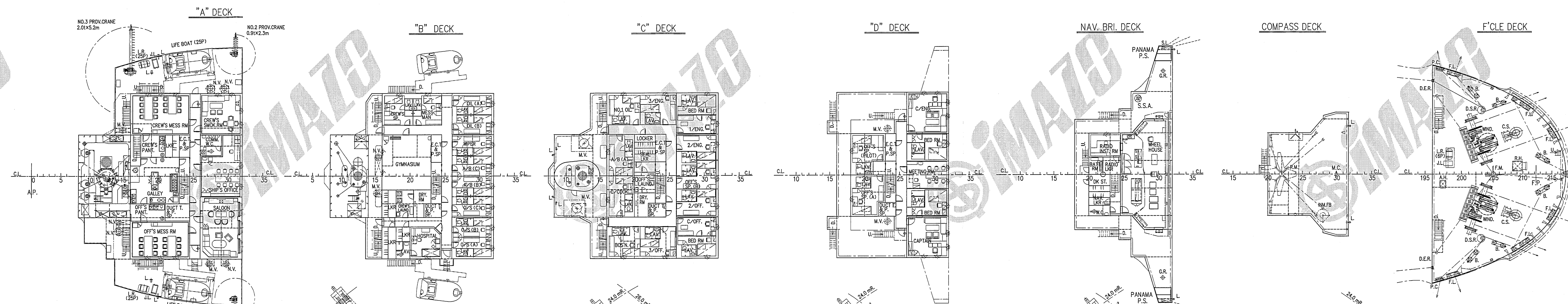

2ND DECK

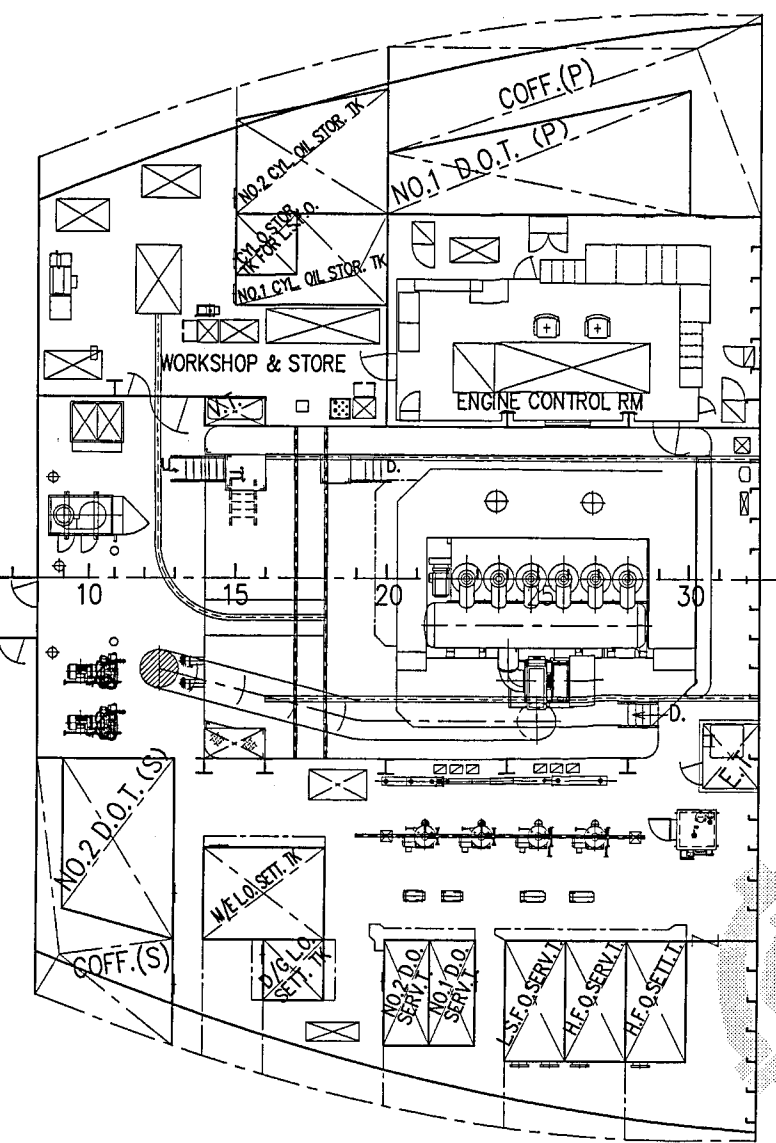

3RD DECK

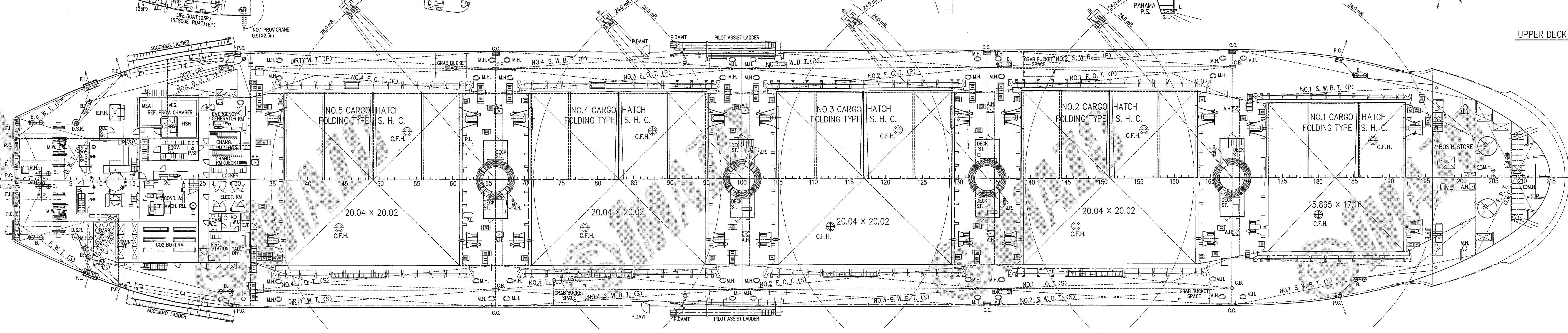
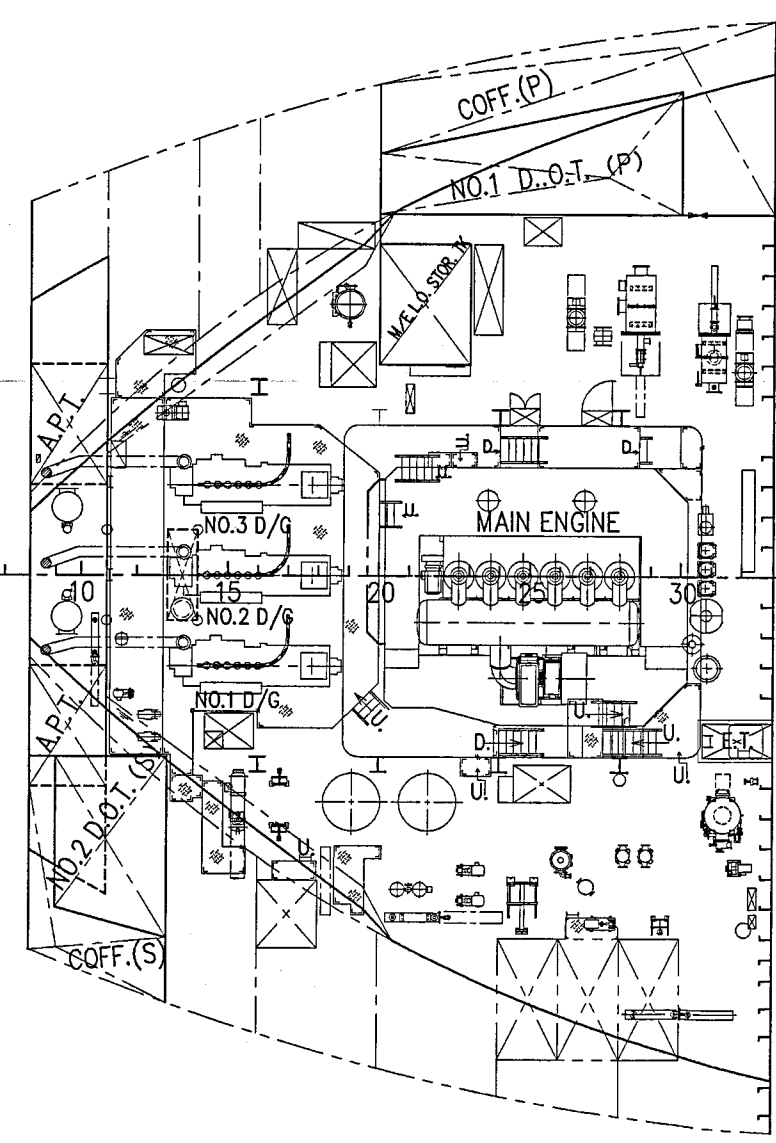

UPPER DECK

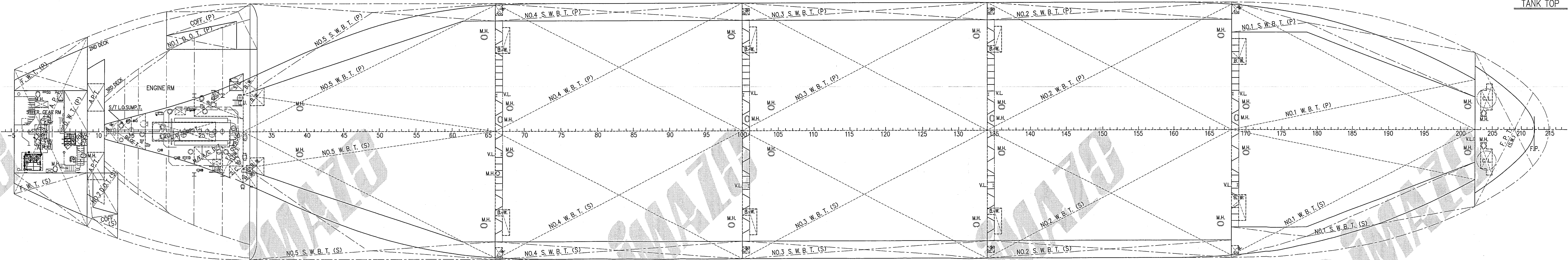

TANK TOP

PRINCIPAL PARTICULARS

LENGTH (O.A.)	179.97 m
LENGTH (B.P.)	173.00 m
BREADTH (M.D.)	29.80 m
DEPTH (M.D.)	15.00 m
DRAUGHT (at SUMMER EXTREME)	10.540 m
DEADWEIGHT (at ASSIGNED DRAUGHT)	37,981 MT
GROSS TONNAGE (L.C.T.M.)	23,234
NET TONNAGE (L.C.T.M.)	12,101
MAIN ENGINE	MARITIME-MITSUBISHI MAN D & W ESSOME - CB2 x 1 set
MAXIMUM CONTINUOUS RATING	6,780 kW x 108 min*
NORMAL OUTPUT RATING	5,215 kW x 90.0 min* (75.9% M.C.R.)
HOLD CAPACITY (GRAIN)	46,934.86 m ³
(BALE)	42,238.33 m ³
SPEED	
SERVICE (at 10.00 m draught) at NOR. Output of M/E 15 S.M.	14.5 knots
TRIAL MAX.	15.85 knots
CLASS	NIPPON KAI KYOKAI (NK)
CLASSIFICATION CHARACTERS	NS * (BULK CARRIER MODIFIED, BC-XI, GRAB, EC CG, PSPC-WBT)
(MS) (ERTS) (EM) / (MS) * (MS)	
DESIGN NOTE	STRENGTHENED FOR HEAVY CARGO LOADING WHERE HOLD NOS. 2 & 4 MAY BE EMPTY/ DOUBLE HULL CONSTRUCTION APPLIED TO ALL CARGO HOLDS
INSTALLATION CHARACTERS	CHG., WPP., LSA., ROT., MO., MFS., BHM

COMPLEMENT

DECK PART	ENGINE PART	BUSINESS PART
CAPTAIN	1 CHIEF ENGINEER	
CHIEF OFFICER	1 1ST ENGINEER	
2ND OFFICER	1 2ND ENGINEER	
3RD OFFICER	1 3RD ENGINEER	
BOATSWAIN	1 NO.1 OILER	1 CHIEF COOK
ABLE SEAMAN	3 OILER	2
ORD. SEAMAN	3 WIPER	1 MESS MAN
TOTAL NUMBER OF OFFICER		8 P.
TOTAL NUMBER OF CREW		13 P.
OFFICER'S SPARE (JUNIOR OFFICER CLASS)		2 P.
CREW'S SPARE (RATING CREW CLASS)		1 P.
OFFICER'S SPARE (PILOT) (JUNIOR OFFICER CLASS)		1 P.
GRAND TOTAL		25 P.

SERIAL NO. B-02

CAUTION
THIS DRAWING OR DOCUMENT IS THE PROPERTY OF IMABARI SHIPBUILDING CO., LTD.
REPRODUCTION, COPYING, UTILIZATION FOR PURPOSES OTHER THAN AGREED, DISCLOSURE TO A THIRD PARTY, ARE STRICTLY SUBJECT TO PRIOR WRITTEN AGREEMENT BY IMABARI SHIPBUILDING CO., LTD.

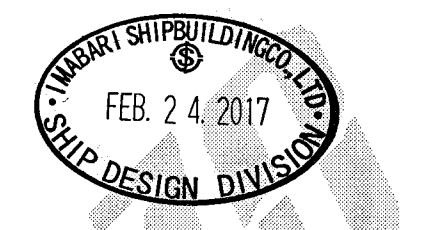

FINISHED PLAN			
CON. NO.	BASIC DESIGN GROUP	SCALE	DWG. NO.
APPROVED	BASIC DESIGN TEAM	1/200	C-0200
CHECKED			
DRAWN			
SHIP NO.	CLASS	SCALE	DWG. NO.
S-A111	NK	1/200	C-0200
IMABARI SHIPBUILDING CO., LTD. I-S SHIPYARD DATE: Feb. 10, 2017			

M.S. "DARYA KAVRI"
IMO 9719137
GENERAL ARRANGEMENT